

 **JUDGE**
Halogen Oven



Recipe Book



Roast Chicken

1 Large chicken approx 2.4kg

2 tsp of sea salt

1 tsp black pepper

1 tsp mixed herbs

2 tbsp olive oil

- 1** Wash the bird and pat dry with kitchen towel, remove the halogen heater lid and place the chicken directly onto the lower rack.
- 2** In a small bowl, mix the olive oil, salt, pepper and herbs and using a pastry brush, brush this mixture all over the bird.
- 3** Replace the halogen lid, set the timer button to 60 minutes and the temperature to 190°C and roast until golden brown. Test the chicken at the end of the cooking time by using a skewer into the leg of the chicken to ensure that the juices run clear. If they are slightly pink, cook for another 10 minutes.
- 4** Use the cooking juices from the chicken to make delicious gravy.



Roasted Vegetables

Serves 2

4 small new potatoes, skins scrubbed but unpeeled

1 red, 1 green, 1 yellow, 1 orange pepper, deseeded and thickly sliced

2 white onions, quartered

10 cloves of garlic left whole with skins still on

12 cherry tomatoes on the vine

3 large chestnut mushrooms, quartered

1 courgette, sliced at an angle

1 tsp of mixed herbs

2 tbsp olive oil

Sea Salt

Black Pepper to taste

- 1 Place all the ingredients into a large round deep roasting dish, tossed with the olive oil, season to taste and sprinkle over the mixed herbs.
- 2 Place in the halogen oven on the lower rack, set the timer to 35 mins and the temperature knob to 210°C.



Jacket Potatoes

Serves 4

4 large sized potatoes

Olive Oil

Sea Salt

- 1 Wash and prick the potato and place in the halogen oven on the bottom rack.
- 2 Set the timer button to 40 minutes and set the temperature to 200°C.
- 3 Remove and serve with the topping of your choice! Its as easy as that!

Cheese Souffle

Serves 6

175g mature cheddar cheese, crumbled

6 Free range eggs, separated

500g crème fraiche

Cayenne pepper to taste

1 garlic clove, crushed

Sea salt and cayenne pepper to taste

2tbs melted unsalted butter

50g freshly grated Parmesan cheese

Pinch of freshly grated nutmeg

Zest and juice of 1 lemon



- 1 Place the cheese, egg yolks, cayenne pepper, salt and crushed garlic in a food processor or blender (a bowl and stick blender will also do the job) and blitz until smooth in texture.
- 2 Add the crème fraiche and blitz again until well blended in.
- 3 In a spotlessly clean stainless steel bowl, whisk the egg whites until they form stiff peaks and then fold this into the creme fraiche mixture.
- 4 Line the inside of each of the 6 ramekins with butter and then sprinkle in the Parmesan cheese to adhere to the buttered sides and base of the ramekins shaking out the excess.
- 5 Pour in the liquid into each ramekin and fill to the $\frac{3}{4}$ level.
- 6 Place on the lower rack in the halogen oven and set the timer to 12 minutes, and the temperature knob to 180°C. Bake until golden brown and nicely risen.
- 7 Sprinkle with the grated nutmeg and serve immediately.

Bread and Butter Marmalade Pudding

75g unsalted butter

75g sultanas

3tbsp dark rum

10 slices brown or white bread

1tbs ginger marmalade

4 egg yolks

1 egg medium

3tbs caster sugar

500ml double cream

200ml full fat milk

1tsp ground ginger

2tbs demarara sugar



- 1 Put sultanas in bowl with the dark rum and microwave for 1 minute.
- 2 Stand and cool and leave to soak for 1 hour.
- 3 Butter both sides of the bread with the melted butter.
- 4 Spread 1 side of each slice with the marmalade.
- 5 Cut in triangles and layer in a round cake pan.
- 6 Mix in the rum flavoured sultanas between the layers of bread.
- 7 Whisk the egg yolks and egg together with the caster sugar.
- 8 Pour the egg mixture in with the cream and milk.
- 9 Pour over the bread and leave to soak for 4 hours.
- 10 Brush the crust with the mixed ginger and demerara sugar.
- 11 Place in the halogen oven on the lower rack setting, turn the timer switch to 30 minutes and then turn the temperature knob to 195°C.
- 12 Dust with demerara sugar and dot with butter, then serve with fresh cream.

Raspberry, blueberry and blackberry Pavlova

Serves 6

3 large egg whites

185g caster sugar

2tsp vanilla extract

½ tsp white wine vinegar

1 rounded tsp cornflour

1 x 300ml tub of double cream

375g mixed raspberries, blackberries and blueberries, washed and drained



- 1 In a spotlessly clean stainless steel mixing bowl, whisk the egg whites using an electric hand mixer until the egg whites are stiff in texture. Now gradually add half of the sugar and beat into the egg whites until well blended in and glossy in texture.
- 2 Fold in the remaining sugar along with the vanilla extract, white wine vinegar and the cornflour.
- 3 Now place the mixture into a piping bag with the appropriate nozzle and pipe the meringue mixture, starting at the centre of the silicon mould and swirling around in a circular motion to cover the whole base. Go around the edge again to give a raised border.
- 4 Place in the halogen oven on the lower rack and set the temperature to 150°C and the timer button to 60 minutes. The meringue should be crisp and dry to the touch, if not bake for a few minutes more.
- 5 Allow to cool slightly in the silicon mould before transferring to a cooling rack. Allow to cool completely.
- 6 When the meringue is cold, whisk the cream in a mixing bowl using a whisk until firm peaks form. Now place in the piping bag and pipe on top of the meringue, then arrange the fruit on top and serve immediately.

Carrot and banana cake

For the cake

2 large ripe bananas, mashed, using a fork

175ml sunflower oil

150g soft dark brown sugar

4 large eggs, lightly beaten

125g carrots, grated

115g sultanas

115g walnuts, bashed into pieces using a rolling pin

Zest of 2 oranges

Juice of 1 orange

1 rounded tsp bicarbonate of soda

1 rounded tsp ground cinnamon

300g plain flour

For the icing

150g Philadelphia cream cheese

100g icing sugar, sifted

Zest and juice of 1 lemon



- 1 Take a square loose bottom Judge square cake pan and grease with butter and line with baking parchment and put aside.
- 2 Place the mashed banana, oil, sugar, eggs, carrots, sultanas, walnuts and the juice and zest of the orange into a large mixing bowl and bring together with a wooden spoon.
- 3 Sift the flour, bicarbonate of soda, cinnamon and the baking powder on top of the wet ingredients and beat in, using an electric hand beater until smooth.
- 4 Pour the mixture into the prepared tin and place into the halogen oven on the lower rack and cook for 35 minutes at 180°C.
- 5 Turn the heat down to 160°C and continue to bake for a further 30-40 minutes or until the cake is cooked through. Test by inserting a metal screwdriver and if it comes out clean then the cake is done.
- 6 Leave to cool slightly in the tin for about 10 minutes then turn out onto a cooling rack and allow to cool completely.
- 7 For the icing beat all the ingredients in a bowl with a wooden spoon and pipe over the cake.

For Further recipes please contact our chef Mal on: www.melandmal.com



Horwood Avonmouth Way Bristol BS11 9HX Great Britain
sales@horwood.co.uk www.judgecookware.co.uk Tel: 0117 940 0000

Cautions

- Before use, check that your mains power supply corresponds to the voltage shown in this manual (also shown on the rating plate of the Oven, located to the rear of the Oven Lid ④).
- Ensure that the sides of the Oven are at least 8cm from any surface.
- The Oven must be placed on a flat and stable surface.
- Do not let children near the Oven when in use.
- Do not let the Power Cable ⑧ hang over the edge of the counter or work-top, or let it touch hot surfaces.
- Do not place the Oven near any other heat source.
- This appliance must be plugged into an earthed socket rated at over 10A.
- Do not place the Glass Bowl ③ directly over any other heat source for cooking.
- Only move the Oven, when operating, with great care. Do not touch hot surfaces; use the Carrying Handles ②. Never lift with the Glass Bowl ③.
- The Glass Bowl ③ and Oven Lid ④ will be HOT after cooking. Always wear Oven mits or use an Oven cloth when handling. The Racks ⑤ & ⑥ may be lifted from the Glass Bowl ③ using the Tongs ⑦ provided.
- After removing the Oven Lid ④, place it on a heat resistant surface, as the underside becomes hot during cooking.
- Do not place the Oven Lid ④ anywhere other than on the Glass Bowl ③ during operation.
- Always place the Oven Lid ④ on the Glass Bowl ③ before connecting the Power Cable and Plug ⑧.
- Do not use the Oven with an external timer switch.
- Do not use the Oven for any purpose other than that for which it is intended.
- Do not drop the Oven.
- Do not share a socket with other appliances, as the socket may overheat.
- Do not immerse the Oven Lid ④ in water or other liquids, or allow liquids to get into the lid.
- Unplug the Oven when not in use.
- Allow the Oven to cool and disconnect from the mains before cleaning.
- Do not clean the Oven with metal scouring pads. Pieces may break off the pad and touch electrical parts, causing damage or risk of electric shock.
- Do not use accessories from any other manufacturer's appliance.
- Do not use the Oven outdoors.
- If the mains supply cable becomes damaged, contact Judge at the address given beneath the warranty statement.
- Do not operate the Oven with a damaged Power Cable or Plug ⑧.
- Do not attempt to repair the unit. In case of breakdown return it to Judge at the address given beneath the warranty statement.

Specification

Name	Model No.	Rated Voltage	Rated Frequency	Rated Power	Rated Capacity
Judge Halogen Oven	JEA30	220 - 240V	50Hz	1200-1400W	12 litres



Judge 2 Year Domestic Electrical Guarantee

The Judge Guarantee covers the product to be free of defects in materials and workmanship for a period of TWO YEARS from the date of original retail purchase. During this period, JUDGE will, at their option, repair or replace defective parts of the product, or replace the product, providing the Use Care and Safety Advice have been followed.

The Guarantee does not cover damage, defect or failure caused by or resulting from accidents, external damage, alteration, modification, abuse, misuse or misapplication.

The Guarantee does not cover any damage caused by taking the appliance apart yourself, or attempting to repair the appliance yourself.

THE PRODUCT IS INTENDED FOR DOMESTIC USE ONLY.

Please keep your Purchase Receipt and contact us directly if you encounter any problems with your product.

HORWOOD SHALL NOT BE LIABLE FOR INCIDENTAL OR CONSEQUENTIAL DAMAGES RESULTING FROM THE USE OF THIS PRODUCT (INCLUDING COLOUR FADING, SCRATCHES OR ACCUMULATED DIRT) WITHOUT FOLLOWING THE USE, CARE & SAFETY INSTRUCTIONS.

Note: Due to the introduction of improvements from time to time, the right is reserved to supply products which differ slightly from those illustrated and described in this publication.

Errors and Omissions Excepted.

JUDGE CUSTOMER SERVICES, HORWOOD, AVONMOUTH WAY,
BRISTOL, BS11 9HX, GREAT BRITAIN

sales@horwood.co.uk www.judgecookware.co.uk Tel: 0117 940 0000



CORRECT DISPOSAL OF THIS PRODUCT



This marking indicates that this product should not be disposed with other household wastes throughout the EU. To prevent possible harm to the environment or human health from uncontrolled waste disposal, recycle it responsibly to promote the sustainable reuse of material resources. To return your used device, please use the return and collection systems or contact the retailer where the product was purchased. They can take this product for environmental safe recycling.

FOR DOMESTIC USE ONLY

JUDGE Halogen Oven



Instruction Manual

Model No. JEA30

**PLEASE READ THIS INSTRUCTION MANUAL CAREFULLY BEFORE
USE AND RETAIN FOR LATER REFERENCE.**

**UNPACK YOUR OVEN CAREFULLY AND REMOVE PACKING PIECES
AND TEMPORARY LABELS & STICKERS.**

Features

The Halogen Oven circulates air heated by halogen technology to cook food quickly and economically, whilst still using conventional culinary techniques. This circulated, hot, dry air method of cooking has many advantages:

1. It can cook most dishes which would normally require a conventional oven.
2. It can roast, bake, grill, steam, reheat or defrost.
3. Electricity consumption is less than half that of a conventional oven.
4. Food is cooked much more quickly than in a conventional oven.
5. Food retains less fat, lowering calorie and cholesterol consumption.
6. Carrying handles allow food to be brought to the table in the oven bowl.
7. It is easily transported, so can be used away from home.
8. Food is cooked evenly, without drying out, burning or smoke.
9. A self cleaning function minimises manual cleaning.

Identifying The Parts

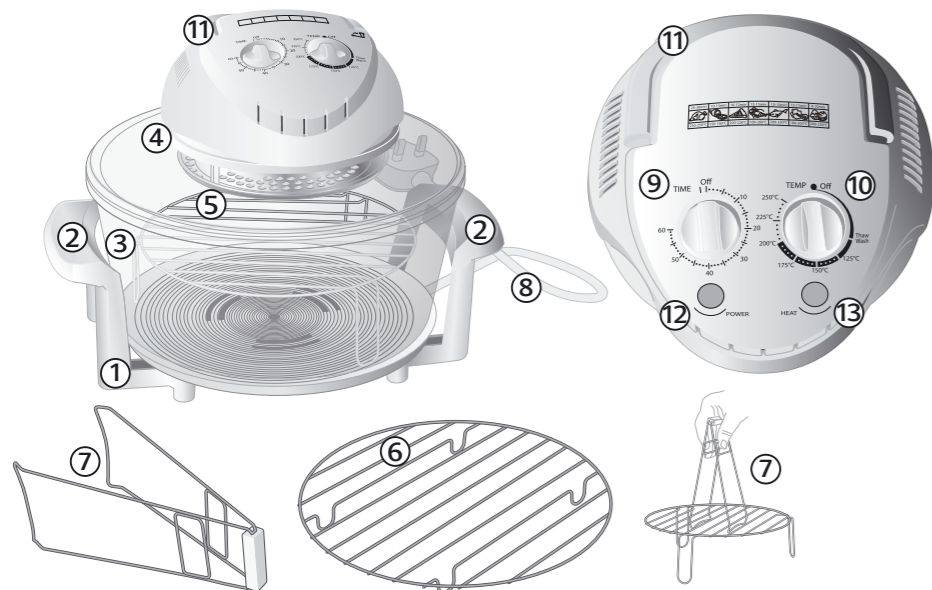

1. Oven base
2. Carrying handles
3. Glass bowl
4. Oven lid, with controls & indicators
5. High rack (shown inside bowl)
6. Low rack
7. Tongs (for lifting racks - see inset)
8. Power cable and plug

- Controls & Indicators**
9. TIME control
 10. TEMP (temperature) control
 11. Handle / ON-OFF switch
 12. POWER indicator
 13. HEAT indicator

Before First Use

1. Wipe the Glass Bowl (3) clean with a damp sponge or dishcloth.
2. Follow steps 3 to 7 of Using The Oven, with a temperature setting of 250°C and a time of 5 minutes, then unplug the Power Cable (8) and allow the Oven to cool.
 - You might notice a slight burning odour while the Oven is running, as lubricants are removed from the heating element.

Using The Oven

1. Place the High Rack (5) or Low Rack (6) centrally in the Glass Bowl (3). The choice of rack depends upon the food to be cooked, with the low rack being used for larger items - see Cooking Guide.
2. Place the food centrally on the rack, ensuring that it is at least 3cm from the wall of the Glass Bowl (3), to allow maximum air circulation.
3. Place the Oven Lid (4) securely and centrally on the Glass Bowl (3). Leave the Handle (11) in the upright OFF position - note the handle label.
4. Plug the Power Cable (8) into the power socket.
5. Set the TEMP control (10) to the required temperature - see Cooking Guide.
6. Set the TIME control (9) to the required time - see Cooking Guide.
7. Immediately lower the Handle (11) to the ON position; both the POWER indicator (12) and HEAT indicator (13) will illuminate.
 - The Oven will heat up rapidly and run for the set time minutes. The HEAT indicator (13) will switch off and back on during this period as the Oven maintains the set temperature. The POWER indicator (12) will remain on until the timer switches off, when a bell will sound, to alert you that the cooking time has been reached.

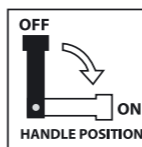

Note: The Glass Bowl (3) and Oven Lid (4) will become hot. Ensure that the Oven is at least 8cm from any surface and take care not to touch the hot areas. Always use Oven mits when handling and lift by the Carrying Handles (2). After removing the Oven Lid (4), place it on a heat resistant surface, as the underside becomes hot during cooking.

Cleaning

Note: Always unplug the Power Cable (8) and allow the Oven to cool before cleaning, including between self cleaning and manual cleaning.

The Oven has a self-cleaning function, which will minimise manual cleaning. To use this, proceed as follows:

1. Pour clean water into the Glass Bowl (3) to a depth of 5cm; for greater cleaning action a small amount of mild dishwashing detergent may be added.
2. Follow steps 3 to 7 of Using The Oven, with a temperature setting of "Wash" and a time of 12 minutes.

For manual cleaning, proceed as follows:

1. Wipe the Glass Bowl (3), Oven Lid and fan housing (4) with a sponge or dishcloth, using a mild dishwashing detergent and warm water.
2. Rinse the Glass Bowl (3) well to remove all detergent.

Note: Never immerse the Oven Lid (4) in any liquid, or allow liquids to get into the lid. Do not use a steel wool pad, abrasive material, solvents or cleaning powders; if scrubbing is necessary, use a nylon or polyester mesh pad.

Cooking Techniques

- **Roasting** - place meats directly on rack.
- **Toasting** - place bread directly on rack; can also bring new life to stale food.
- **Baking** - place food in a metal or tempered glass baking pan, up to 30cm dia.
- **Steaming** - place food in an aluminium foil pouch with a small amount of water.
- **Frying** - dip food in cooking oil, allow excess oil to drain and place directly on rack, or in heat resistant container.
- **Defrosting** - set temperature to "Thaw" and check every 5-10 minutes.
- **Cooking from frozen** - reduce suggested temperature on packaging by 20°C, suggested cooking time by 30-50%.
- Remember to distribute food evenly in the Oven to ensure an even flow of air around the food.
- You may wish to spray the racks with a non-stick food spray before use to prevent the food sticking.

Cooking Guide

Note: This is a guide only and supplements the guide on the lid. Observe the food cooking and ensure that it is thoroughly cooked before serving. It may be necessary to use a container to prevent small food items, such as chips, falling through the rack.

	Cooking time	Temp	Rack Position
Roast Beef or Lamb	35 min/kg + 20 min	180-190°C	low rack
Roast Pork	55 min/kg + 20 min	180-190°C	low rack
Steak: rare to well done	3-7 min each side	250°C	high rack
Sausage	5-8 min each side	250°C	high rack
Pork or Lamb Chop	6-8 min each side	250°C	high rack
Chicken	20-30 min/kg + 15 min	190-250°C	low rack
Chicken Parts	15-20 min	190-200°C	high rack
Fish	10-15 min	200-220°C	high rack
Pizza	10-13 min	150-180°C	high rack
Small Cakes and Buns	8-10 min	200-230°C	low rack
Cake - one layer	20-25 min	200°C	low rack
Loaf	35-40 min	150°C	low rack
Chips/French Fries	10-20 min	200°C	high rack